

## Disassembly/Operation Checks/Reassembly Procedures

### COMMON . . . . . ITEMS FOR EACH PROCEDURE

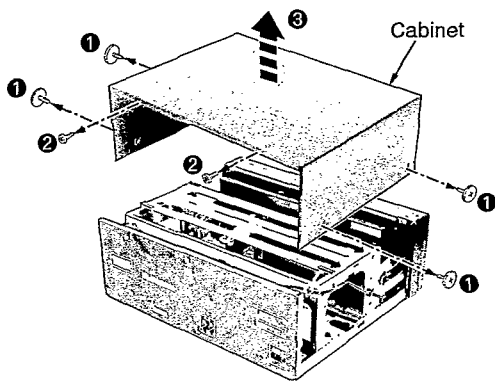

- ①, ② Remove the 6 screws.
- ③ Remove the cabinet.

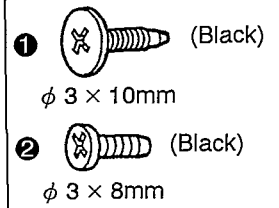

※ The numbers reversed in white indicate the order of procedures.  
 ※ The screw illustrations are equivalent to actual size.

### PRIOR TO THE OPERATION CHECKS

The following DISASSEMBLY/OPERATION CHECKS/REASSEMBLY procedures consist of 3 main items.  
 Follow the appropriate procedures to the failed block.

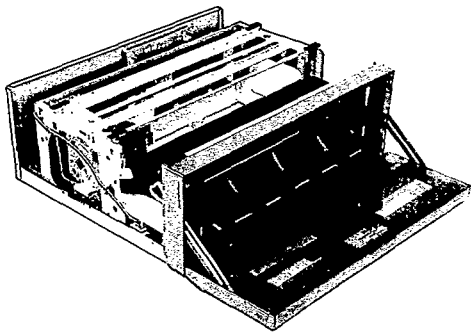

- Each block are described in order to the followings. **DISASSEMBLY**
- **OPERATION CHECK**
- **REASSEMBLY**

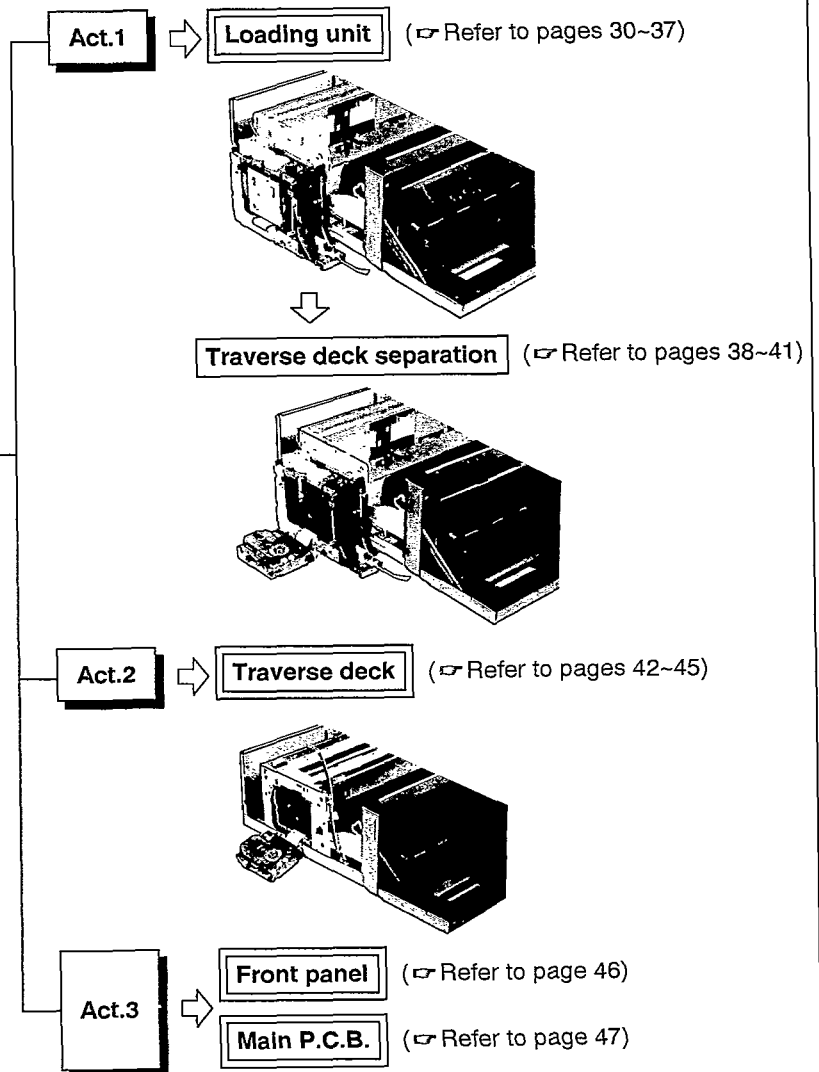

## ■ Repair Guide

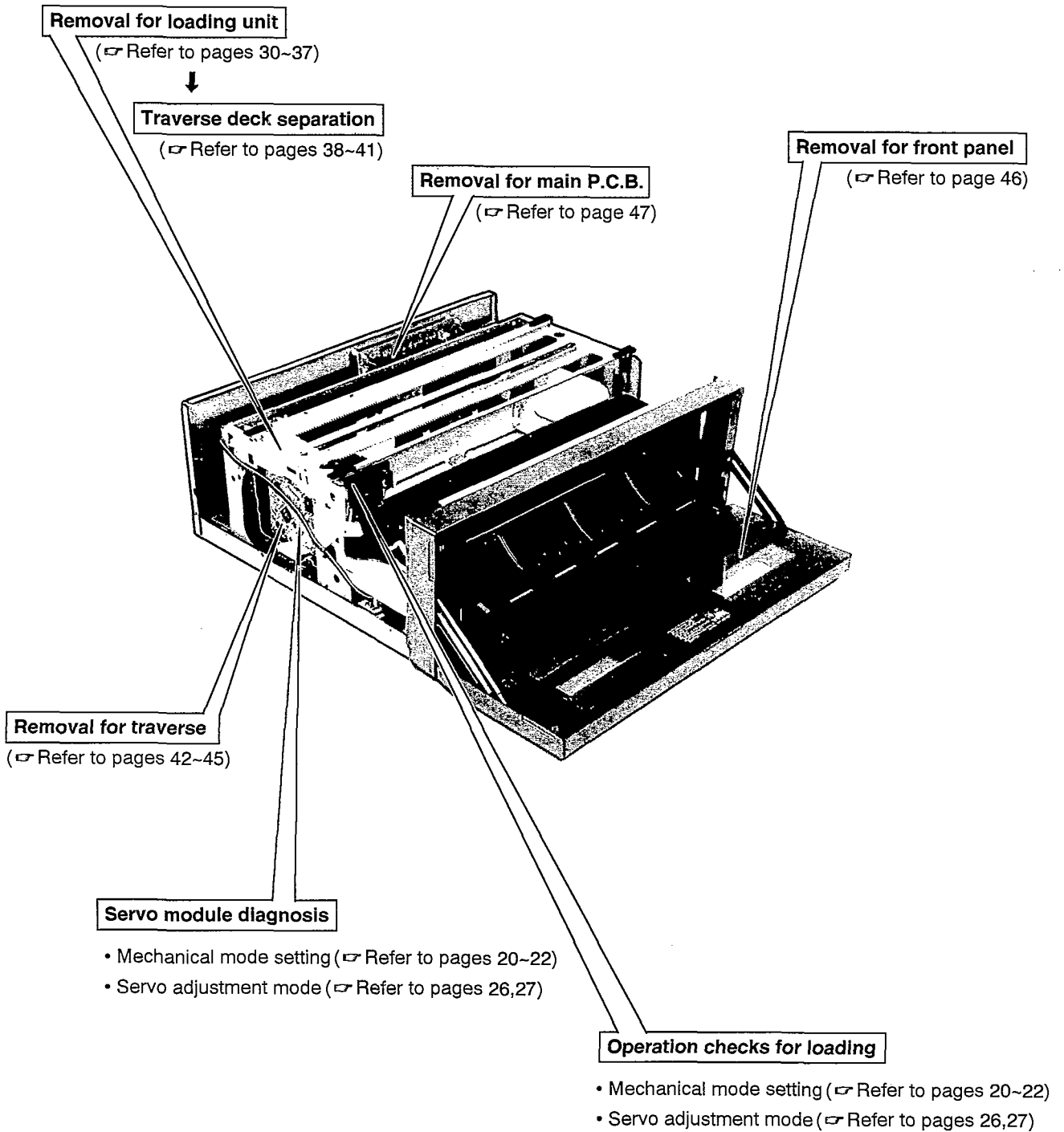

### Precaution

- Handling of the loading unit (☞ Refer to pages 30)

## Precaution

### Handling of the loading unit

- During the loading unit disassembly/operation checks/reassembly, handle the following parts carefully .

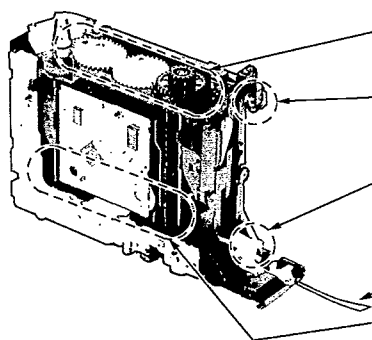

**Each travel gear**

- Check each gear for rotating in assembly.

**LED and Photo coupler**

- Dust, incorrect position and etc.

**Front feed lever**

- Broken, deformation and etc.

**Each loading gear**

- Check each gear for rotating in assembly.

## Act.1 Loading unit Disassembly

### Handling of the loading unit

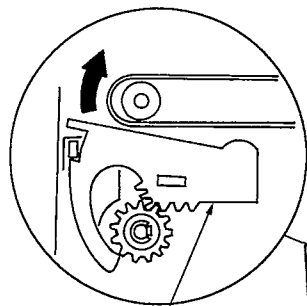

① Front lock gear

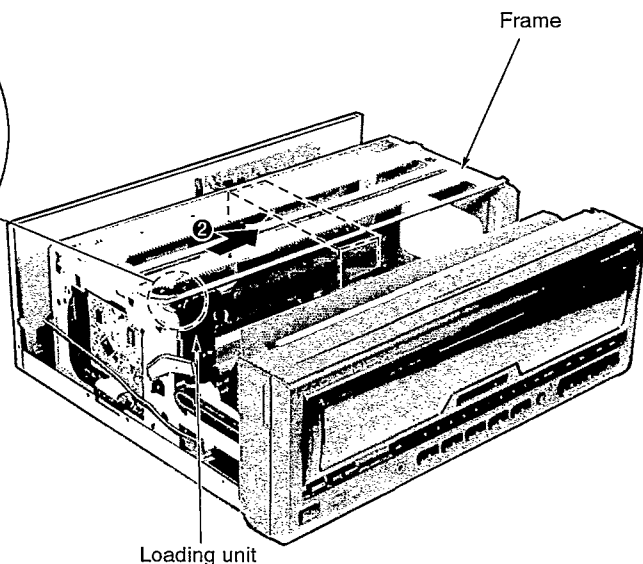

- ① Unlock the loading unit by moving the front lock gear manually in the direction of arrow.

- ② Move the loading unit manually in the right direction.  
(Move the loading unit to the right direction beyond the center of the frame.)

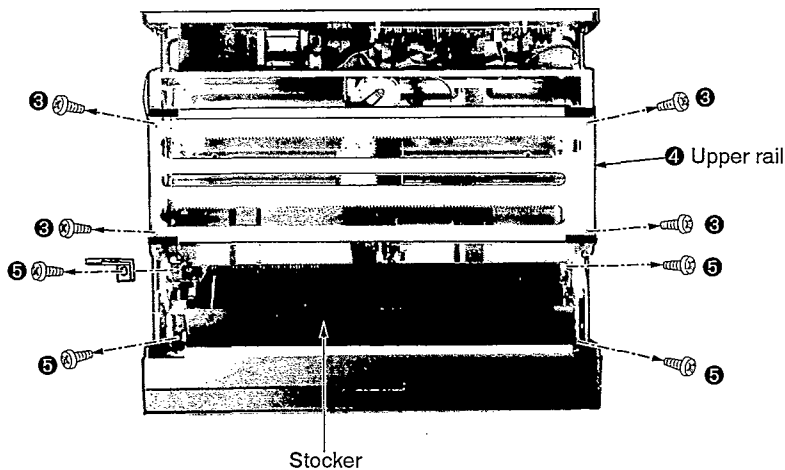

- ③ Remove the 4 screws for upper rail.  
④ Remove the upper rail.  
⑤ Remove the 4 screws for stocker.

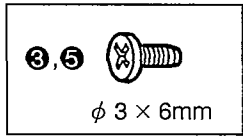

**Act.1 Loading unit Disassembly**

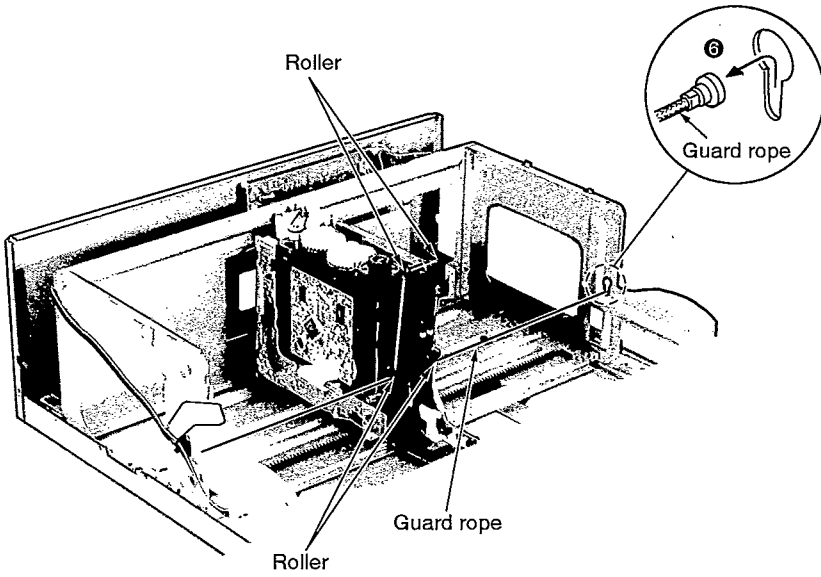

⑥ Remove the guard rope.

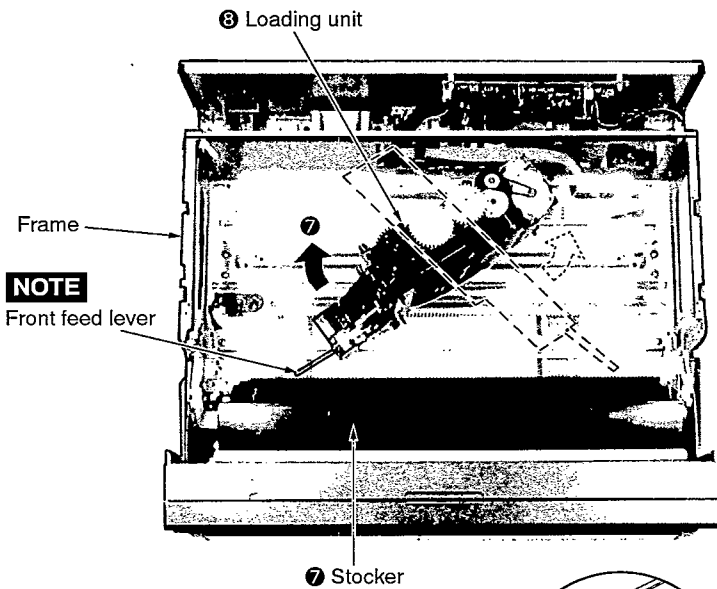

**NOTE**

When removing the loading unit, make sure to avoid the front feed lever from the stocker and then, lift up the loading unit because the front feed lever is positioned under stocker.

**NOTE**

When removing the loading unit, make sure to avoid the front feed lever from the stocker and then, lift up the loading unit because the front feed lever is positioned under stocker.

- ⑦ Rotate the loading unit to clockwise or counterclockwise with lifting the stocker and then, slide the front feed lever under the stocker.
- ⑧ Remove the loading unit from frame.

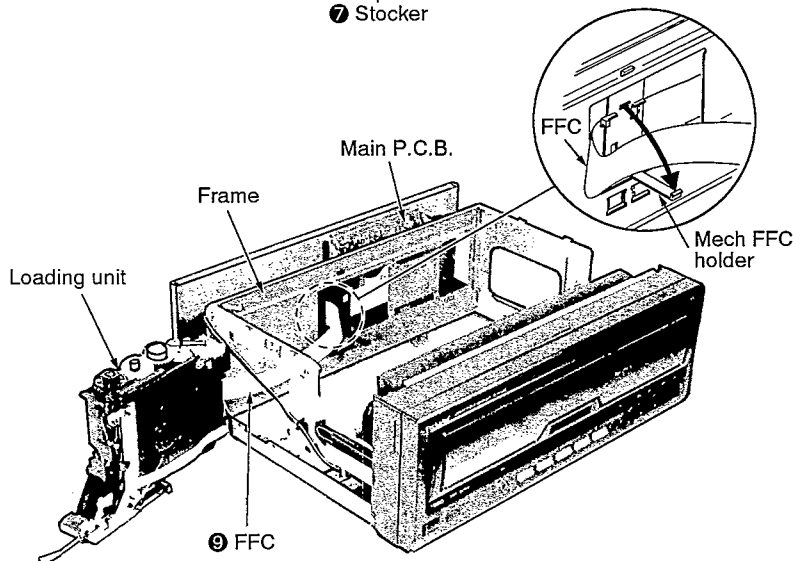

⑨ Remove the mech FFC holder.

⑩ Remove the FFC from loading unit. Then, reconnect the FFC to the loading unit through the opening of frame.

Preparation for operation checks is completed.

## Act.1 Loading unit Operation checks

### ■ Test mode

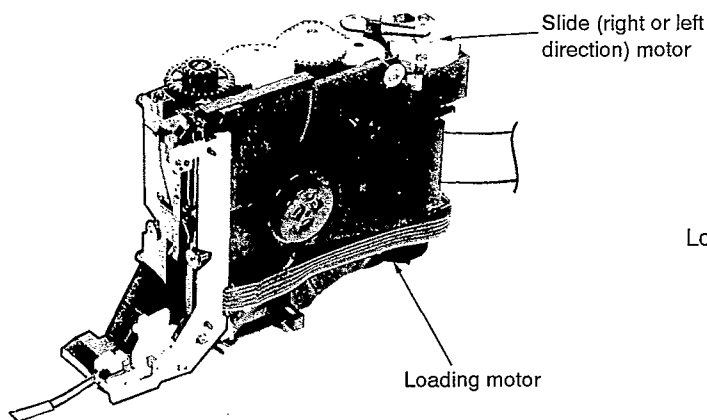

※ This operation can be executed without traverse deck (including servo module).

- ① Set to the test mode and then, push the button **B** on front panel (☞ Refer to page 24)
- ② The slide(right or left direction) motor rotates for approximate 20 seconds.
- ③ Then, the loading motor rotates with repeating the following operation.

Load → (Stop for 1 second) → Unload → (Stop for 1 second)

**Make sure there are no unusual noise, binding or running over visually.**

- ④ To relieve the operation, set to the power off.

### ■ Manual operation (For this operation, remove the parts described in "Test mode", and more the parts as follows.)

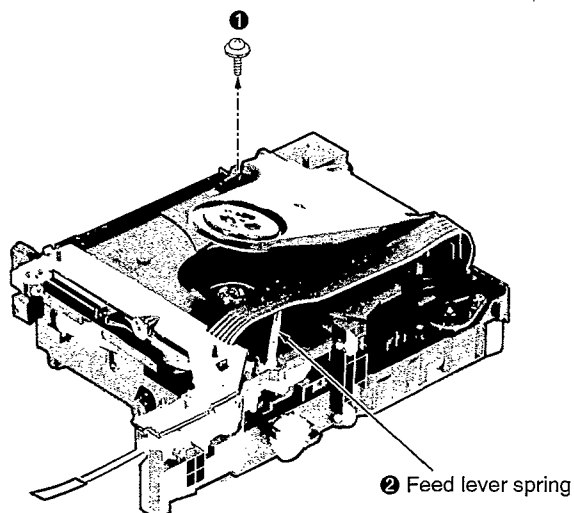

- ① Remove the 1 screw.
- ② Remove the feed lever spring.

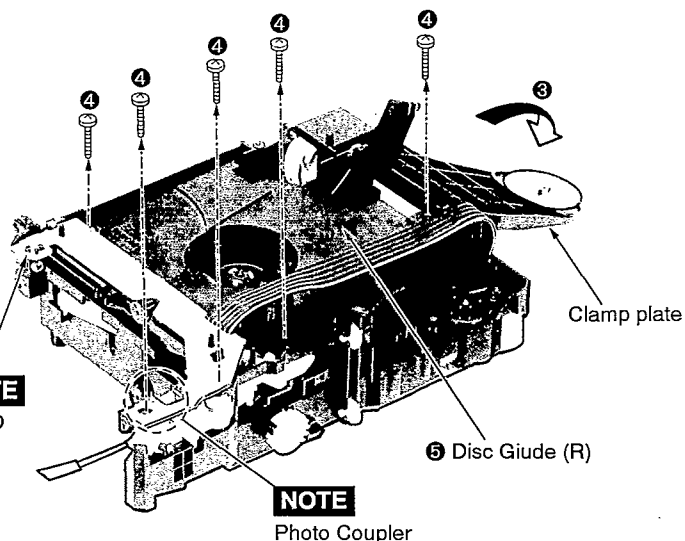

- ③ Tilt the clamp plate backward.
- ④ Remove the 5 screws.
- ⑤ Remove the disc guide (R).

#### NOTE

Take care not to touch the LED or photo coupler by hand.

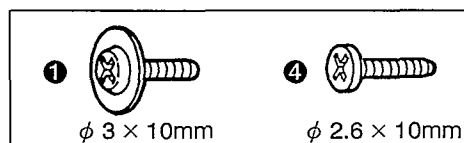

Act.1	Loading unit	Operation checks
-------	--------------	------------------

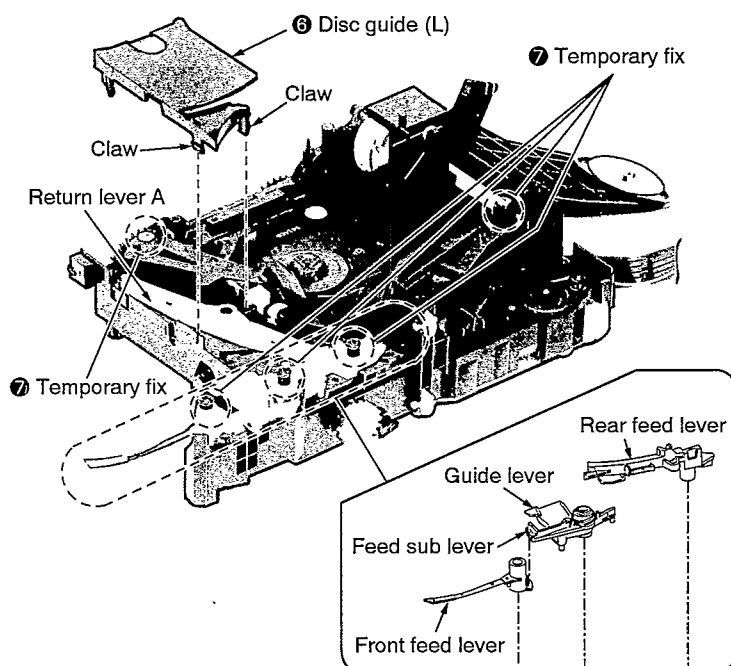

⑥ Release the 2 claws and then, remove the disc guide (L).

⑦ In this manual operation, the rear/front feed levers, guide lever ass'y, etc. may be removed because the disc guides(L/R) are removed already.  
Temporary fix those levers with 5 screws.

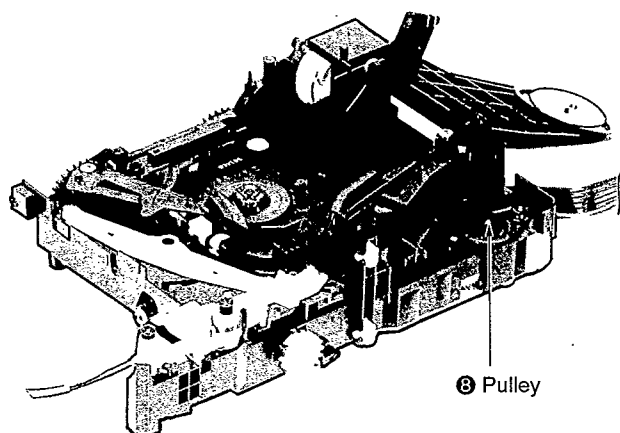

⑧ In case of confirmation manually, rotate the pulley as shown left.

- Rotate clockwise : Loading operation
- Rotate counterclockwise : Unloading operation

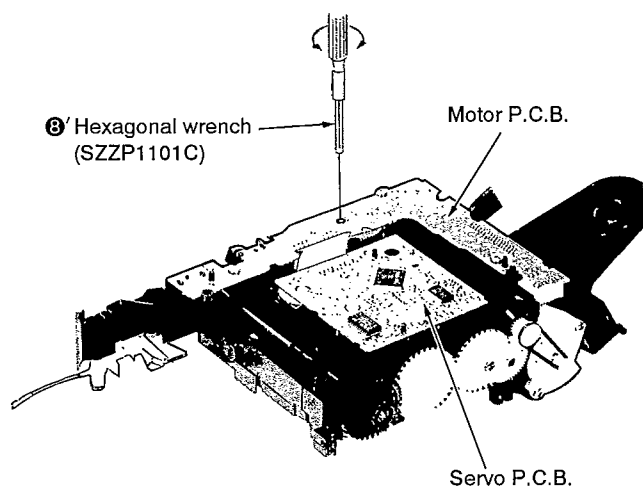

⑧' Or rotate with 2 mm hexagonal wrench (SZZP1101C).

- Rotate clockwise : Unloading operation
- Rotate counterclockwise : Loading operation

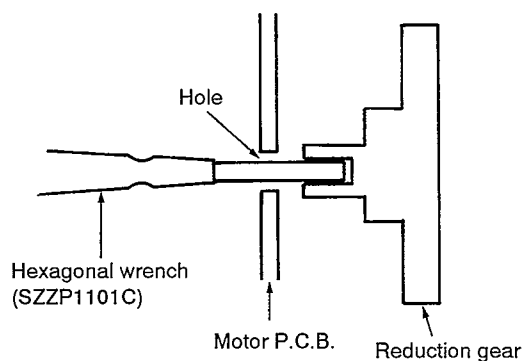

**Act.1 Loading unit Reassembly**

■ **In Test mode** ..... Follow the items ① ~ ②.

■ **In Manual operation** ..... In case that the parts fixed temporary are removed, the perform the items ① ~ ⑩ and then, follow the items ⑪ ~ ⑫.

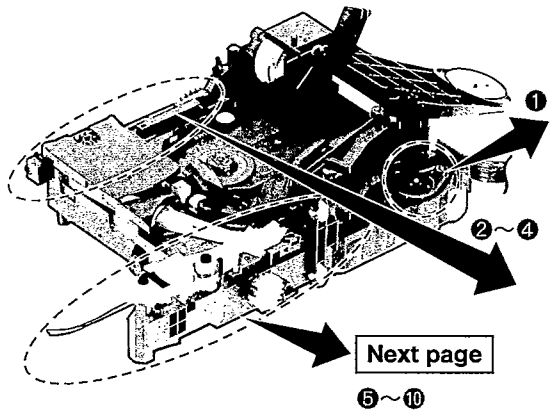

① Rotate the pulley clockwise fully.

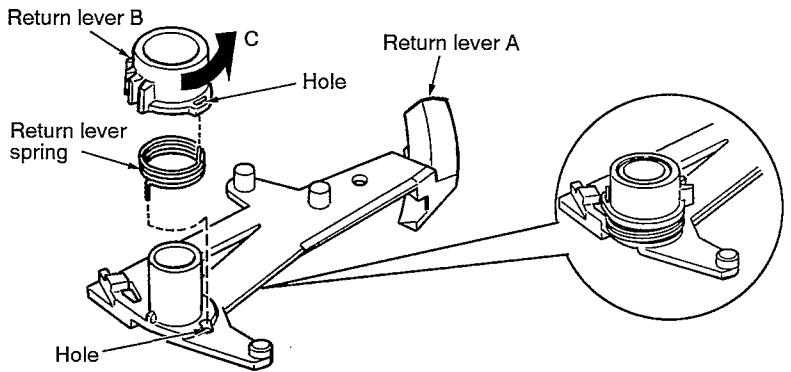

② Return lever A

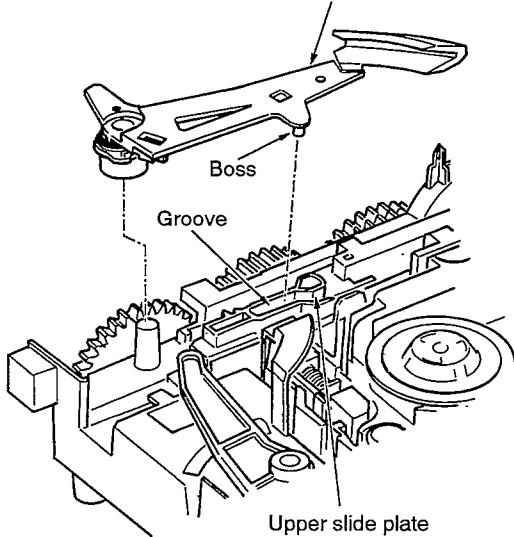

② Align the both ends of the spring with the holes of return lever A and B and then, install the return lever A with rotating the return lever B in the direction of arrow (→) C.

③ Install the return lever A.  
(Align the boss of return lever A with the groove of upper slide plate.)

④ Disc guide (L)

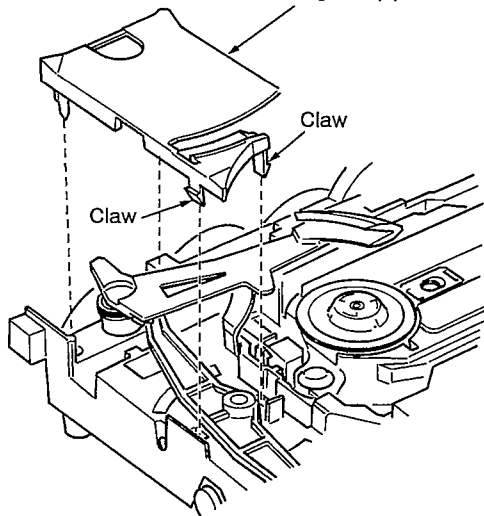

④ Install the disc guide(L).  
(Press the disc guide (L) until the claws are hooked completely.)

**Act.1 Loading unit Reassembly**

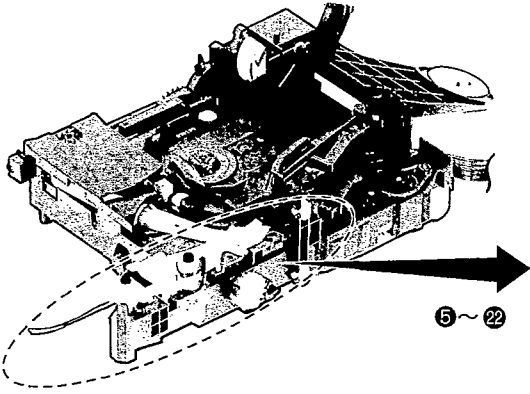

[The state of pulley rotated clockwise fully.]

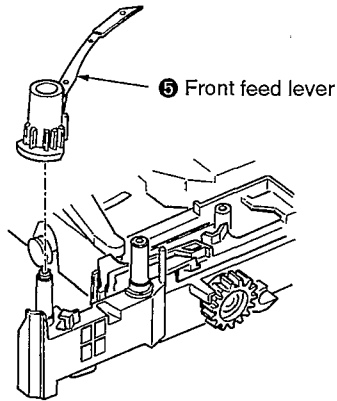

5 Install the front feed lever.

**NOTE**

Avoid the front feed lever to deform or bend.

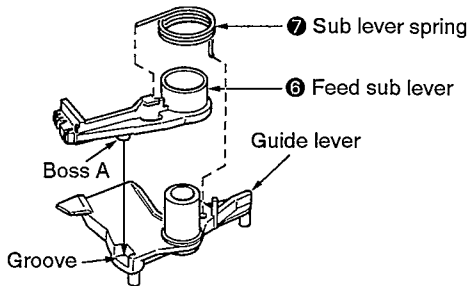

6 Install the feed sub lever to the guide lever.  
 • Align the boss A of feed sub lever with the groove of the guide lever.

7 Install the sub lever spring.

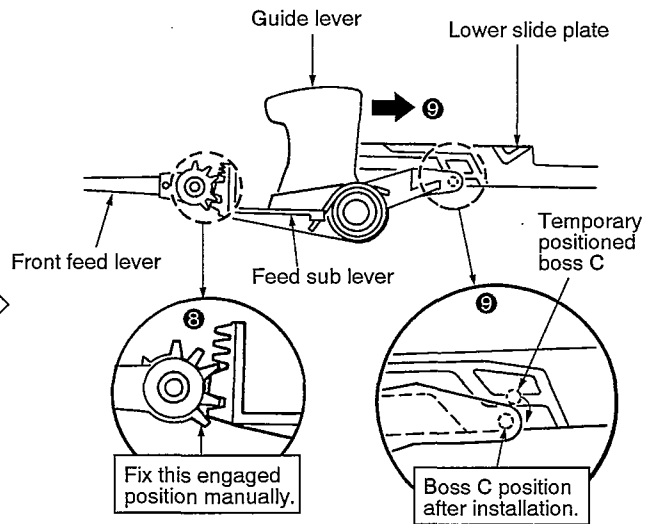
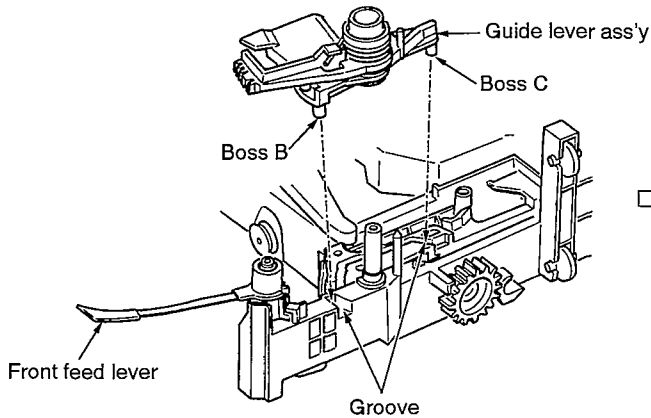

8 Engage the gear of guide lever ass'y with the gear of front feed lever temporary.  
 • Boss B must be placed in the groove.  
 • Boss C must be run over the lower side plate.

9 With fixing the gear by finger not to slip off the gear clench, rotate the guide lever in the direction of arrow.  
 • The boss C will fit in the groove.

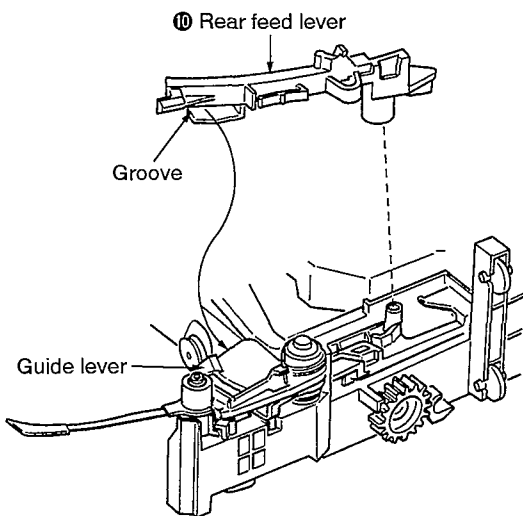

10 Install the rear feed lever.  
 (Align the guide lever with the groove of rear feed lever.)



**Act.1 Loading unit Reassembly**

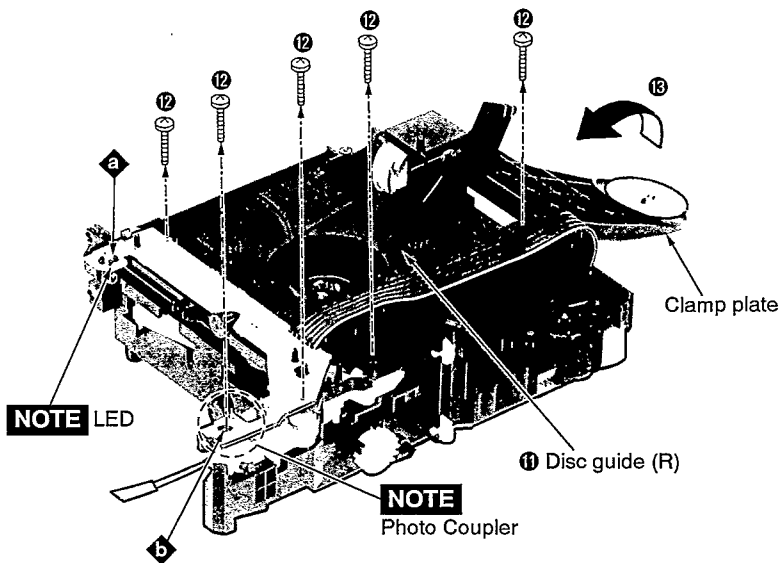

11 Install the disc guide(R).

**NOTE**

Align the claw of disc guide with the slot **a**.

12 Install the 5 screws.

**NOTE**

Align the upper portion of boss inserted sensor holder with the slot **b**, and then tighten screw.

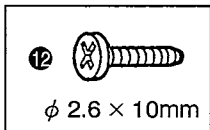

13 Tilt the clamp plate forward.

**NOTE**

Take care not to touch the LED or photo coupler by hand.

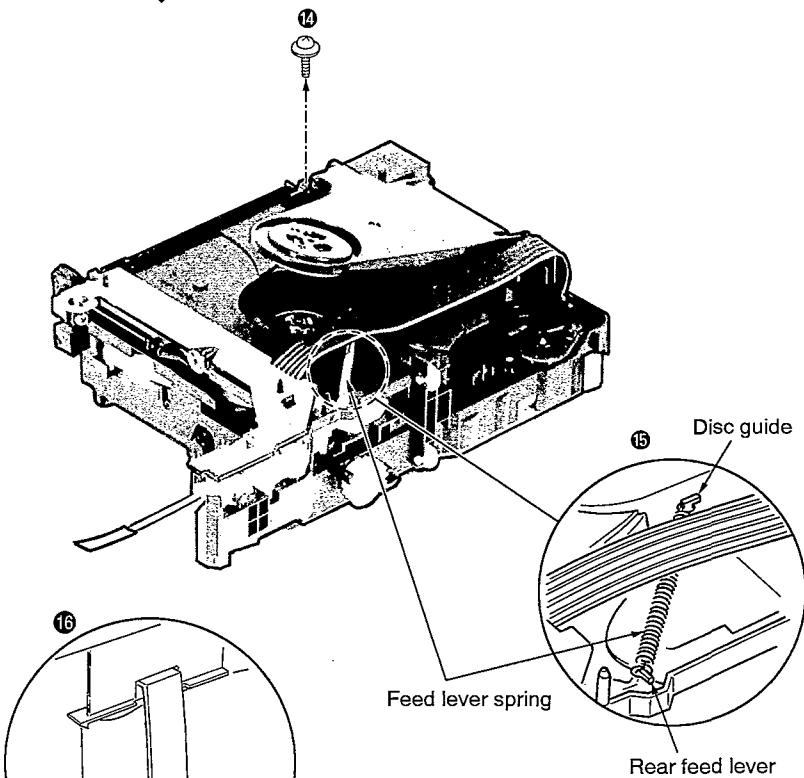

14 Install the 1 screw.

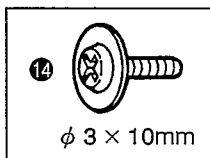

15 Install the feed lever spring.

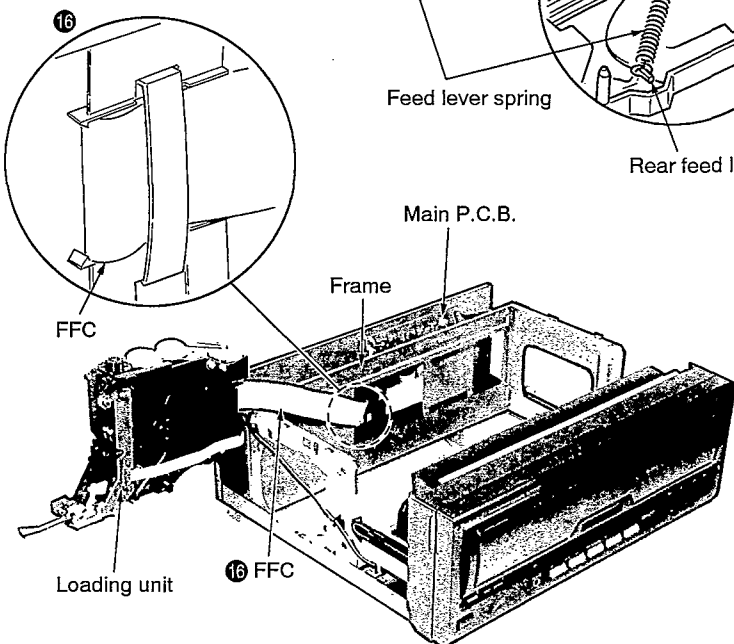

16 Remove the FFC from loading unit. Then, reconnect the FFC to the loading unit over the frame.

**Act.1 Loading unit Reassembly**

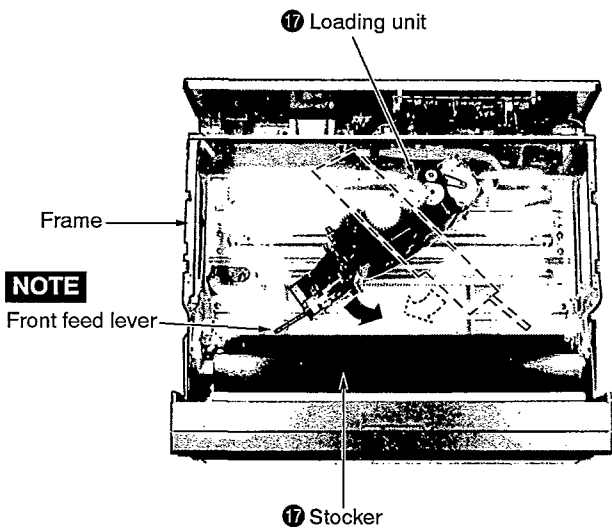

**NOTE**

**NOTE**

When reassembling the loading unit, make sure to avoid the front feed lever from the stocker and then, install the loading unit because the front feed lever is positioned under stocker.

- ⑰ Rotate the loading unit counterclockwise or clockwise with lifting the stocker and then, place the front feed lever under the stocker.

- ⑱ Hang the guard rope with the spring side (left side).

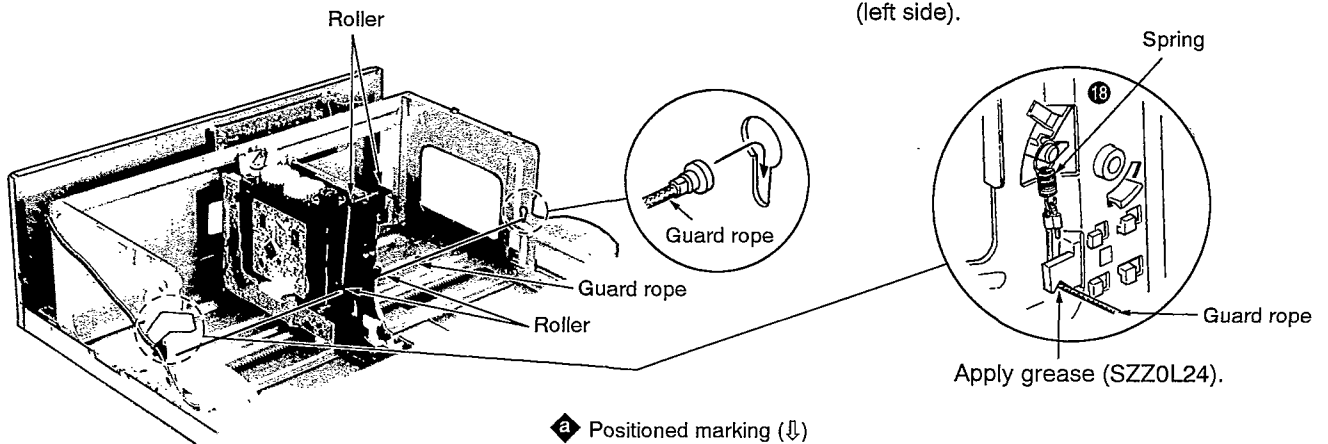

- ◆ a Positioned marking (↓)

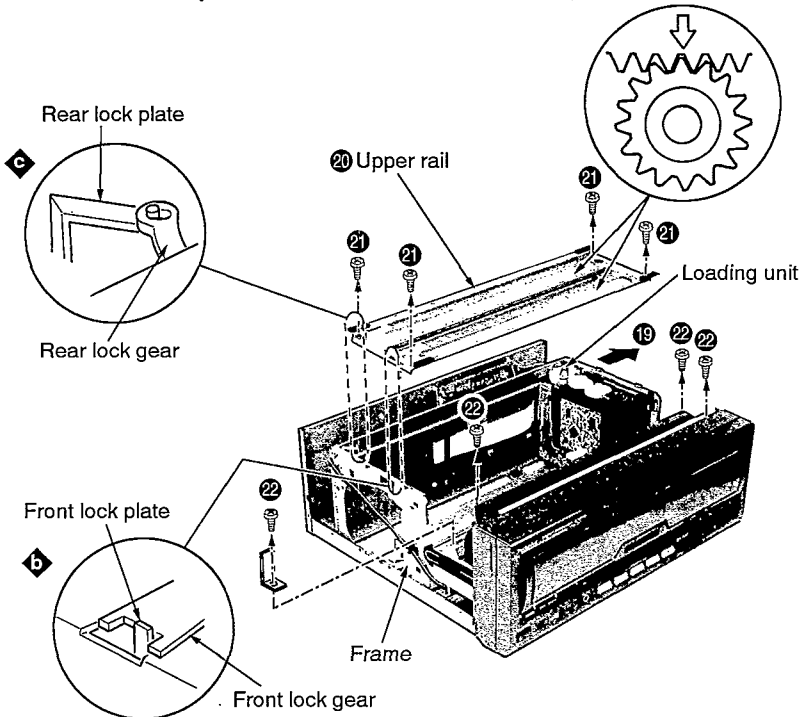

- ⑲ Move the loading unit to the right end of frame.
- ⑳ Install the upper rail to the frame. Then, make sure to perform the following operations.

- ◆ a Align the front travel gear and rear travel gear with the marked position of upper rail.
- ◆ b Engage the front lock gear with the front lock plate.
- ◆ c Engage the rear lock gear with the rear lock plate.

- ㉑ Install the 4 screws for upper rail.
- ㉒ Install the 4 screws for stocker.

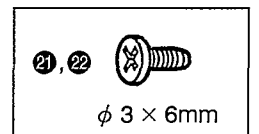

**Act.1 Traverse deck separation Disassembly**

The followings are described the procedures to make the traverse deck part from loading unit after removed the loading unit block from the frame.

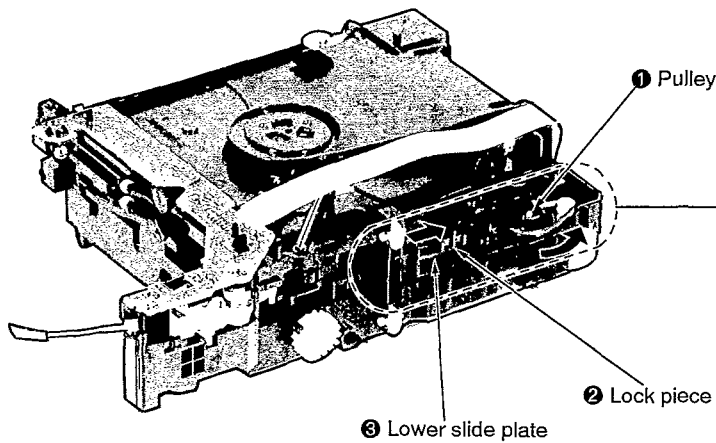

① Rotate the pulley counterclockwise.

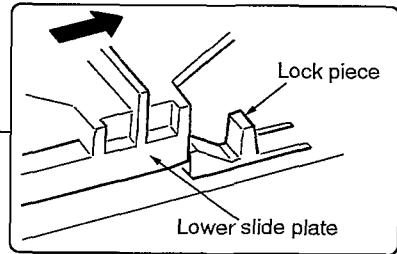

Rotate the pulley until the lower slide plate is moved in the direction of arrow and then touched to the lock piece.

② Rotate the pulley counterclockwise fully with pressing the rib of lock piece.

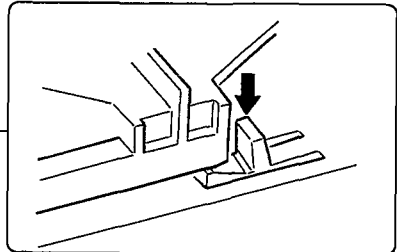

The lower slide plate runs over the lock piece.

③ Slide the lower slide plate manually in the direction of arrow until the lower slide plate touches the rib of lock piece

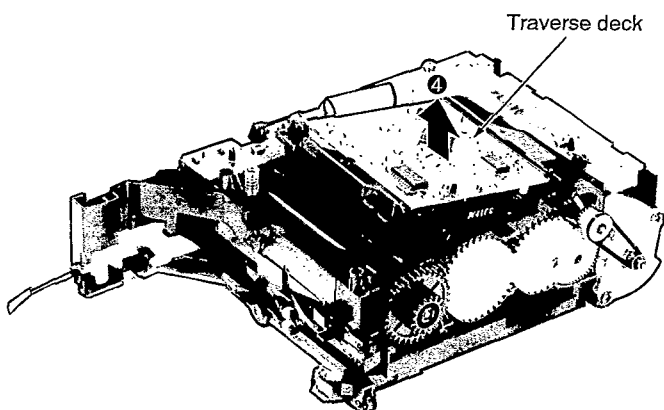
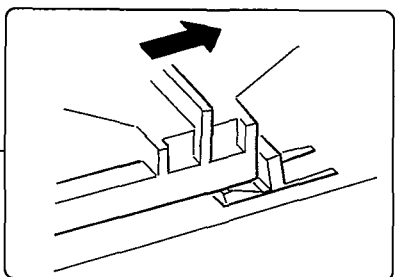

④ Upset the loading unit and then, lift up the traverse deck.

## Act.1 Traverse deck separation Operation check

### ■ Focus operation confirmation

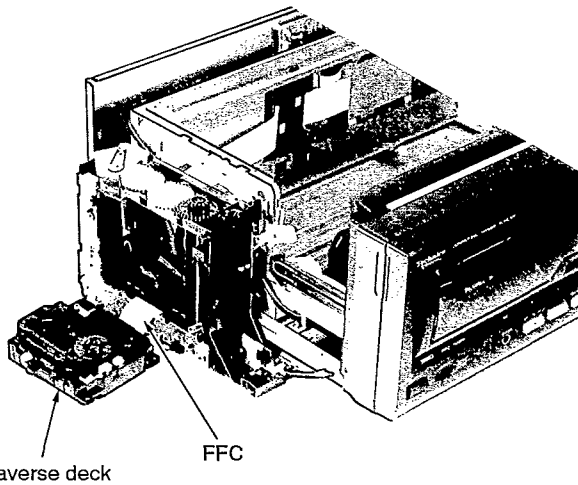

① Set the switch to TEST MODE.  
(☞ Refer to page 23)

② Press the button **A** on the operation panel.

Standby the traverse deck to Individual operation.



Press the PLAY(▶) button.



Confirm the focus operation visually.

### ■ Servo module confirmation

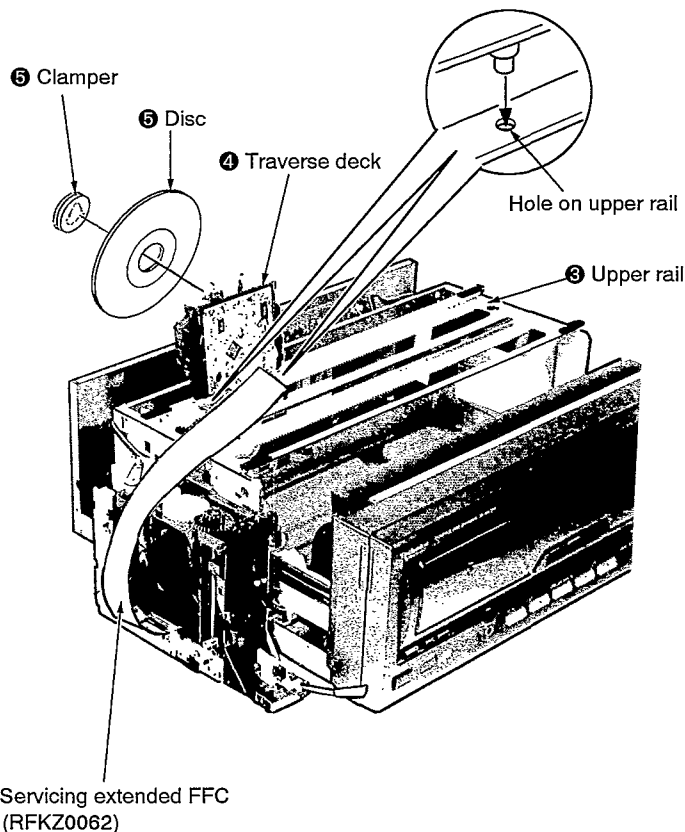

① Remove the FFC between the traverse deck and loading unit.

② Connect the servicing extended FFC between the traverse deck and loading unit.

③ Install the upper rail.  
(The screws are not necessary for fixing.)

④ Locate the servo module faced to you and then, align the traverse deck with the hole on upper rail.

⑤ Attach the disc to the clamper with magnet.



Preparation for operation checks is completed.

⑥ Set the switch to TEST MODE.  
(☞ Refer to page 23)

⑦ Press the button **A** on the operation panel.



Standby the traverse deck to Individual operation.



Press the PLAY(▶) button.



CD play starts.



Check the servo module.

**Act.1** Traverse deck separation Resassembly

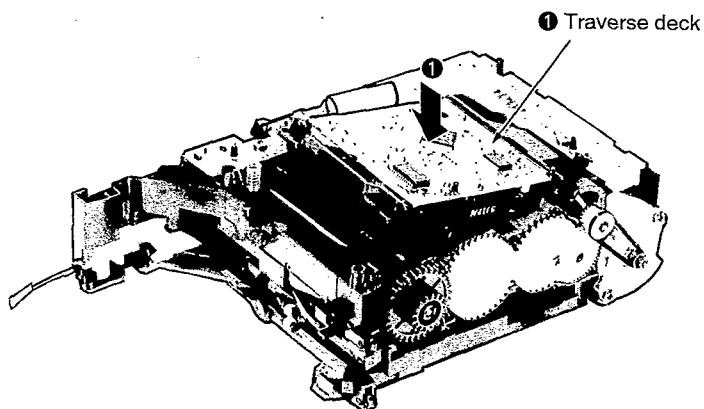

① Equip the traverse deck with the loading unit.

② Slide the lower slide plate in the direction of arrow with supporting manually not to be fall free the traverse deck.

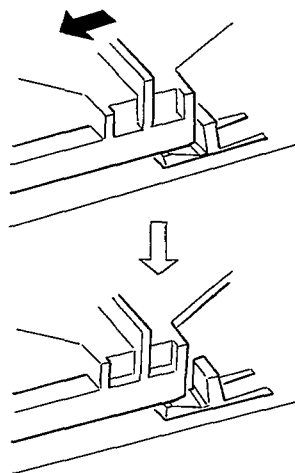

The traverse deck will not fall free as shown above.

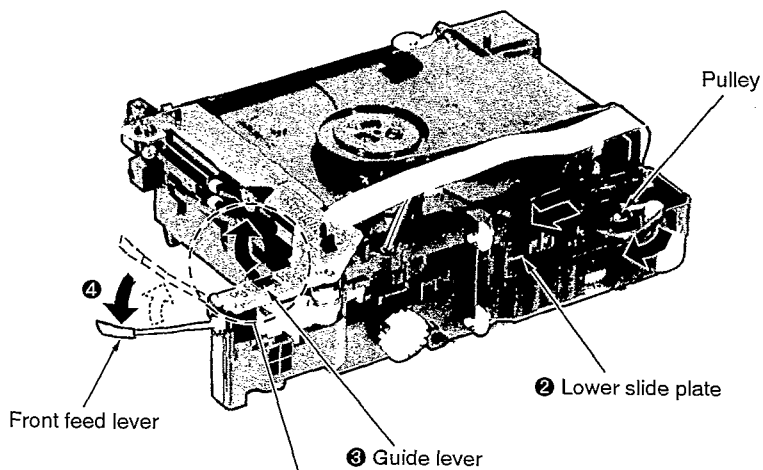

③ While pushing the guide lever in the direction of arrow, rotate the pulley clockwise.



To easy installation loading unit into the frame, rotate the pulley fully clockwise.

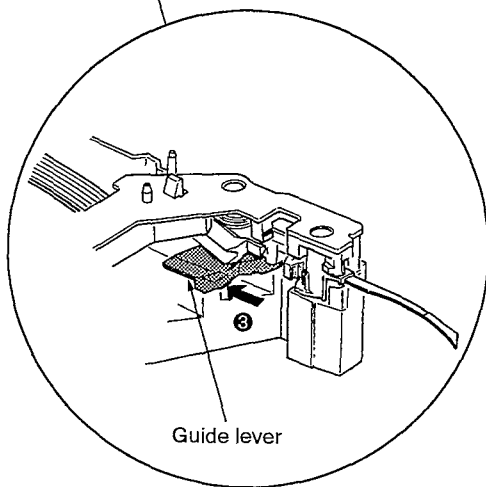

**Confirmation**

During the above operation, make sure that the front feed lever rotates to clockwise (Dot line) once and then, return to original position(Full line).

## Act.1 Traverse deck separation Reassembly

### ■ In case that the operations described in item "Confirmation" are not to be performed.

- In case that the operations described in item "confirmation" are not to be performed (The front feed lever will not return to original position (Full line) and is fixed at position indicated with dot line), perform the following operations.

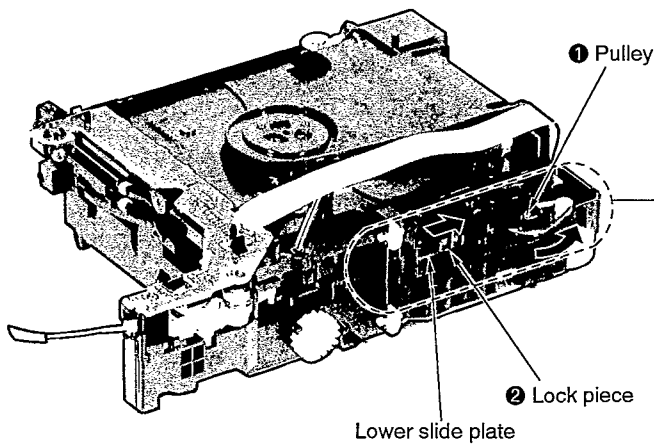

① Rotate the pulley counterclockwise.

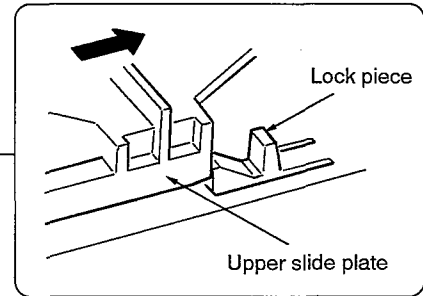

Rotate the pulley until the lower slide plate moves in the direction of arrow and touches the lock piece.

② With pushing the rib of lock piece, rotate the pulley counterclockwise fully.

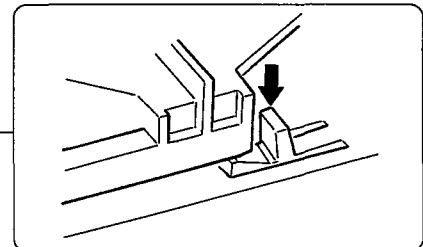

The lower slide plate runs over the lock piece.



Rotate the pulley counterclockwise with pushing the guide lever as shown item ③ on page.

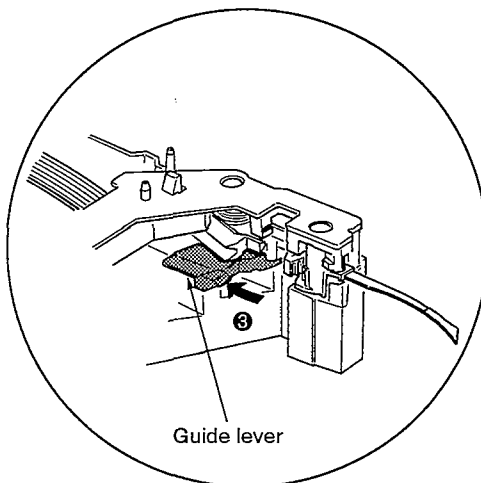

## Act.2 Independent traverse deck Disassembly

- The traverse deck can be removed individually without removal of loading unit.
- It is very convenient to perform the operation checks for traverse deck quickly.

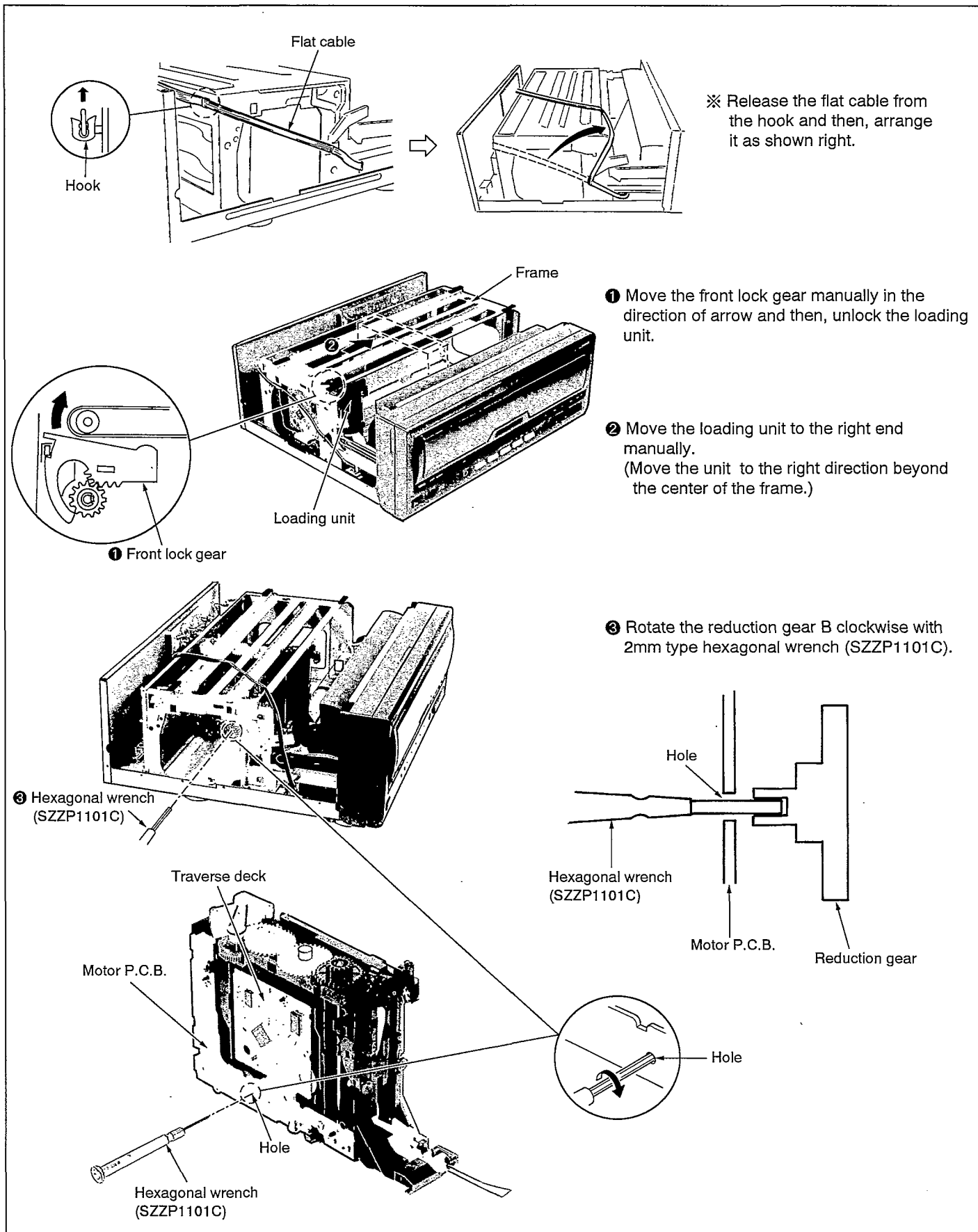

**Act.2 Independent traverse deck Disassembly**

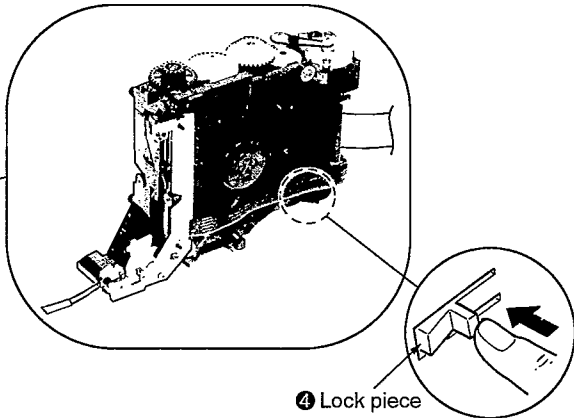
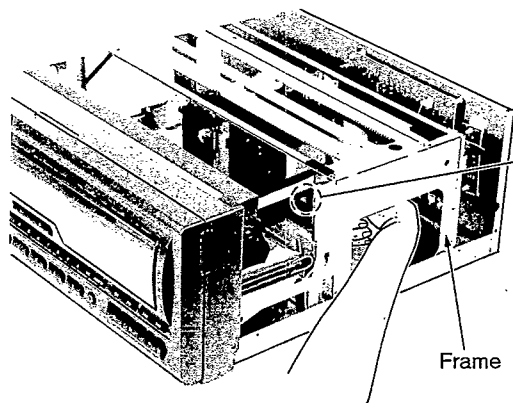

**NOTE**

Handle the edge of frame with care.

- ④ Put the right hand into the right side of frame and then, pressing the lock piece, rotate the hexagonal wrench to clockwise.

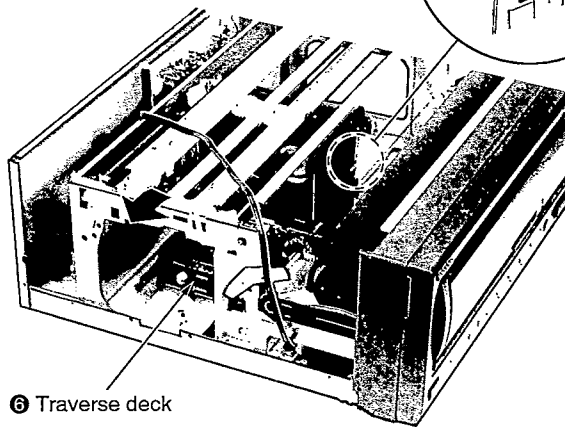
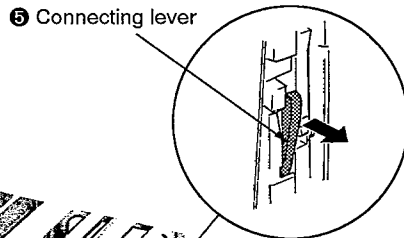

- ⑤ Pull the connecting lever in the direction of arrow.
- ⑥ Separate the traverse deck from the loading unit.

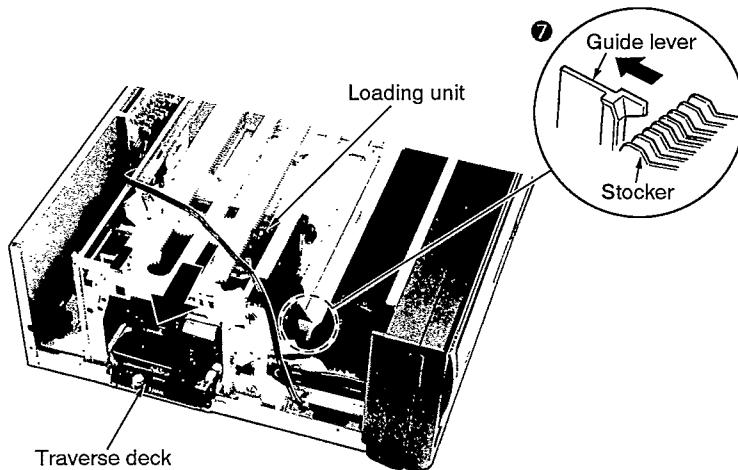

- ⑦ Move the guide lever in the direction of arrow and then, move the loading unit to the left end with relieving the engagement to stocker.



## Act.2 Independent traverse deck Operation checks

### ■ Focus operation confirmation

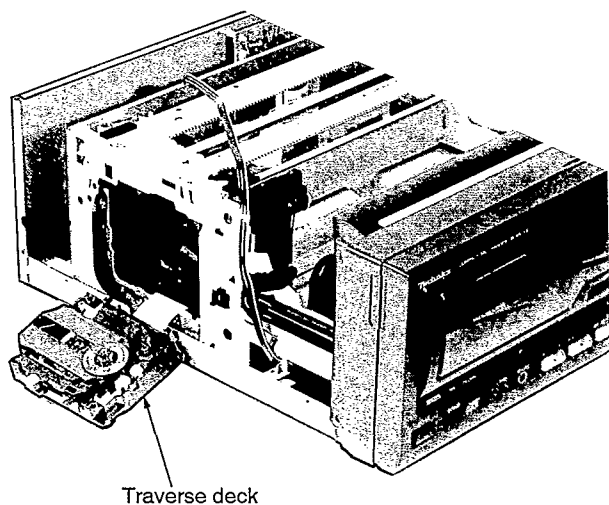

- 1 Set the switch to TEST MODE.  
(☞ Refer to page 23)

- 2 Press the button **A** on the operation panel.

Standby the traverse deck to individual operation.

Press the **PLAY(▶)** button.

Confirm the focus operation visually.

### ■ Servo module confirmation

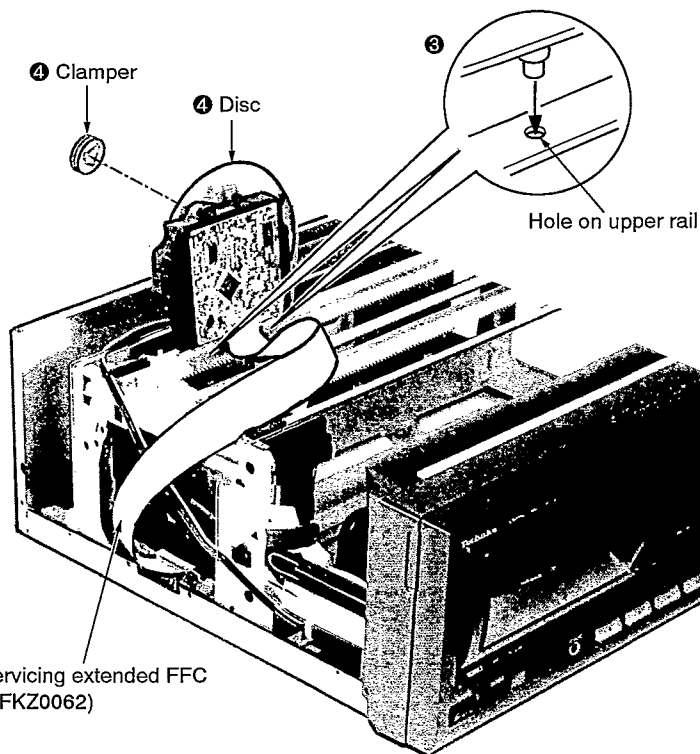

- 1 Remove the FFC between the traverse deck and loading unit.
- 2 Connect the servicing extended FFC between the traverse deck and loading unit.
- 3 Locate the servo module faced to you and then, align the traverse deck with the hole on upper rail.
- 4 Attach the disc to the turn table with clamper (magnet).

Preparation for operation checks is completed.

- 5 Set the switch to TEST MODE.  
(☞ Refer to page 23)
- 6 Press the button **A** on the operation panel.

Standby the traverse deck to individual operation.

Press the **PLAY(▶)** button.

CD play starts.

Check the servo module.

## Act.2 Independent traverse deck Reassembly

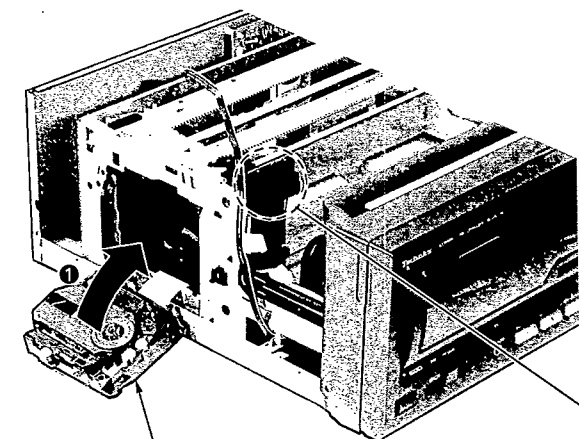

Traverse deck

Loading unit

- ① Equip the traverse deck with the loading unit.
- ② Push the guide lever in the direction of arrow with supporting manually not to be fall free the traverse deck.

The traverse deck will not fall free as shown above.

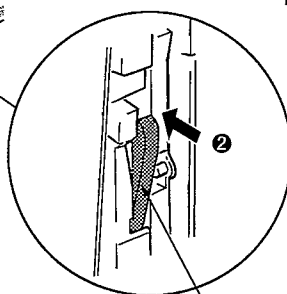

Connecting lever

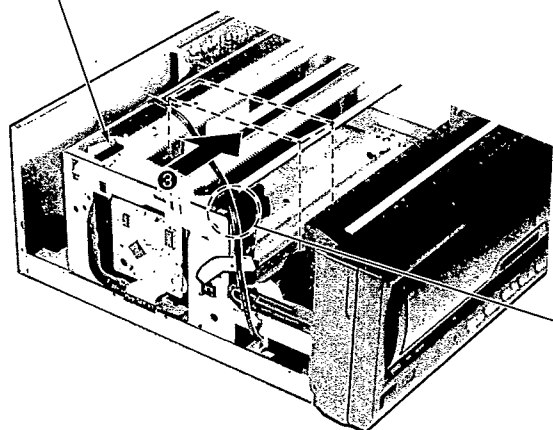

- ③ Move the guide lever in the direction of arrow and then, move the loading unit to the center with relieving the engagement to stocker.

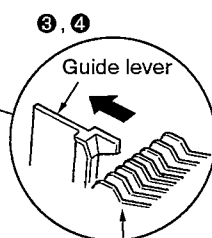

Stocker

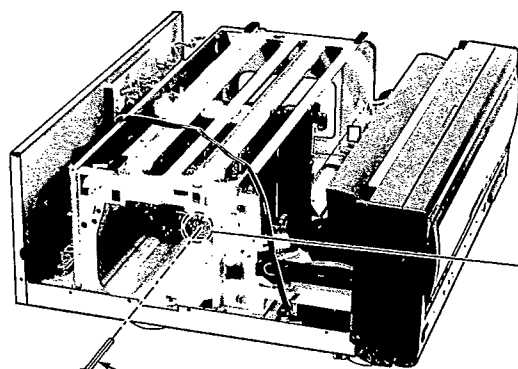

④ Hexagonal wrench (SZZP1101C)

- ④ With keeping the guide lever in the direction of arrow, rotate the reduction gear to counterclockwise fully with 2mm type hexagonal wrench(SZZP1101C)

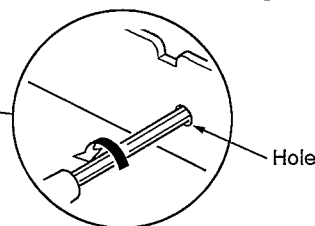

Hole

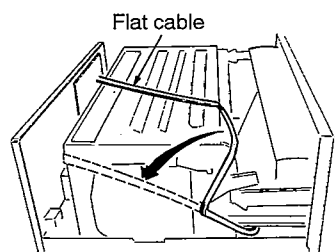

Flat cable

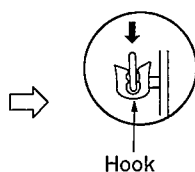

Hook

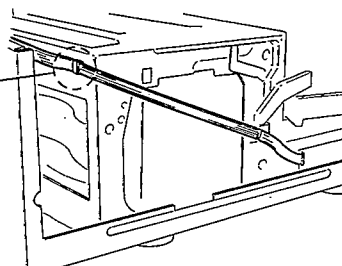

※ Arrange the flat cable in original form.

**Act.3 Front panel Disassembly**

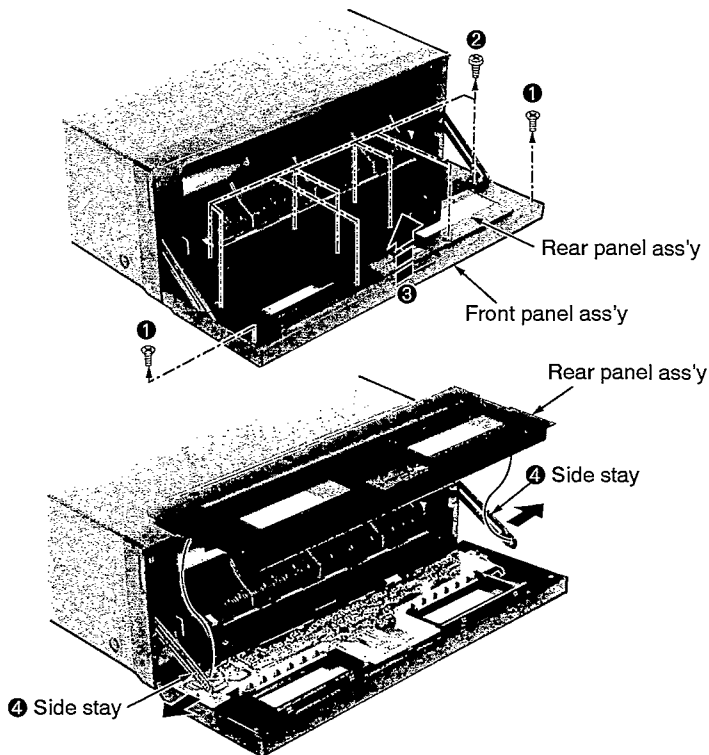

- ① Remove the 2 countersunk screws.
- ② Remove the 10 screws.
- ③ Lift up the rear panel ass'y.

- ④ Remove the rear panel ass'y with releasing the both side stays.

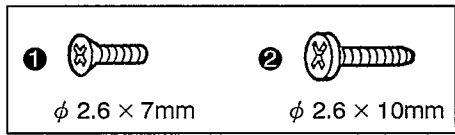

**Act.3 Front panel Operation checks**

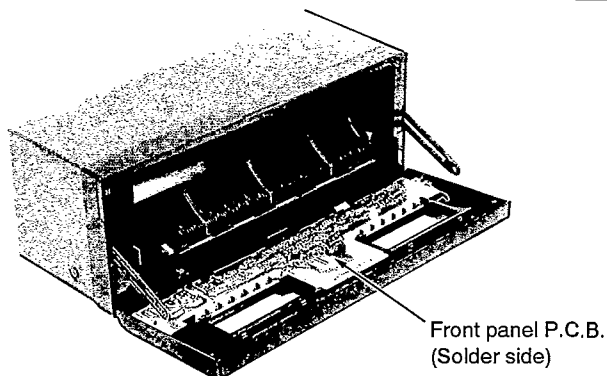

- Perform the operation checks in the state as shown left.

**Act.3 Front panel Reassembly**

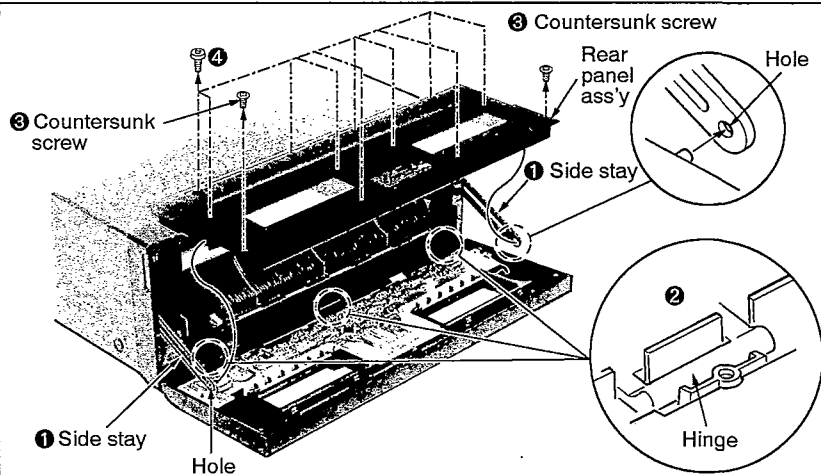

- ① Align the both of back panel with the hole of side stays.
  - ② Install the hinges to the rear panel ass'y.
  - ③ Install the 2 countersunk screws.
- Make sure that the countersunk screws are in correct position.**
- ④ Install the 10 screws.

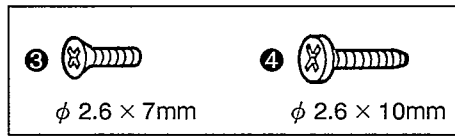

### Act.3 Main P.C.B. and disc signal P.C.B. Disassembly

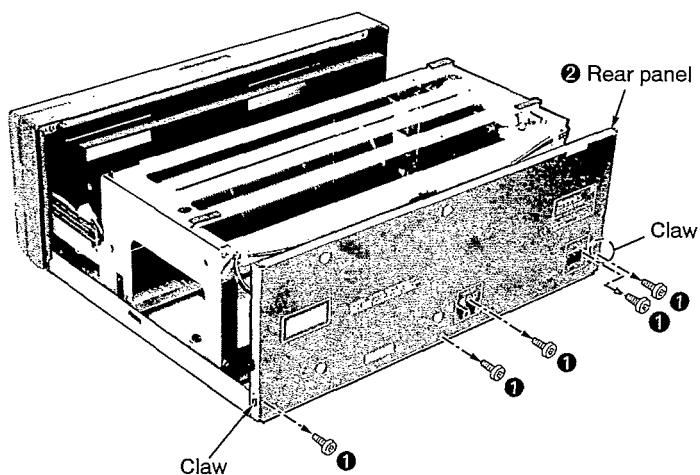

① Remove the 5 screws.

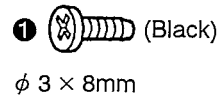

② Release the 2 claw, and then remove the rear panel.

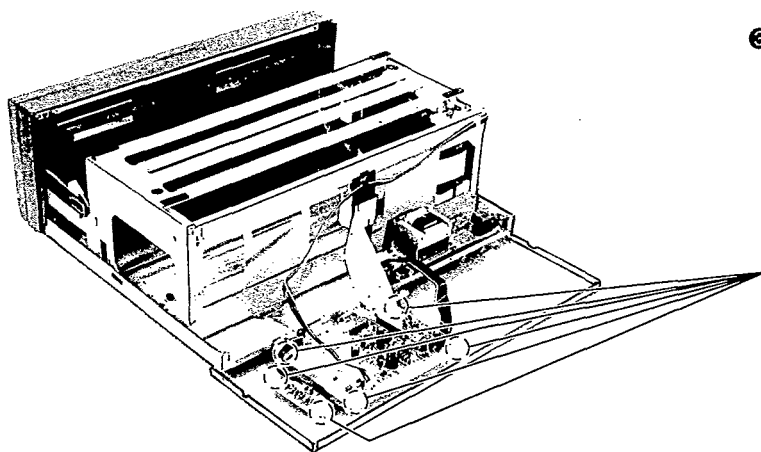

③ Release the P.C.B. supports from the main P.C.B.. (Pinch the claws of P.C.B. supports with plier as shown below.)

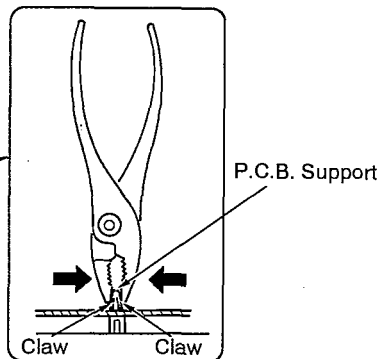

### Act.3 Main P.C.B. and disc signal P.C.B. Operation checks

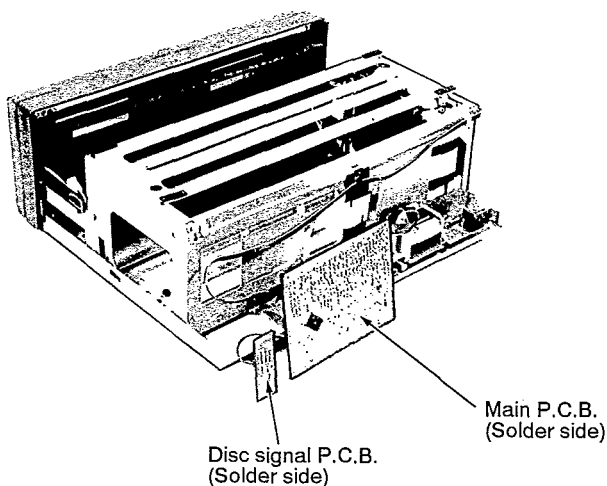

• Perform the operation checks in the state as shown left.

### Act.3 Main P.C.B. and disc signal P.C.B. Reassembly

For reassembly after operation check, perform in reverse order of disassembly (①-③).